

ClampOn®

WOODWORKER



2" MINI CHUCK SET

PART NO: 6501662

USER INSTRUCTIONS

ORIGINAL INSTRUCTIONS

DL0524

INTRODUCTION

Thank you for purchasing this CLARKE product. The Chuck Kit is designed for use with the CLARKE CWL325V Mini Woodlathe. Ensure that all components are present. Should any loss or damage be apparent, please contact your CLARKE dealer immediately.

The following components are supplied.

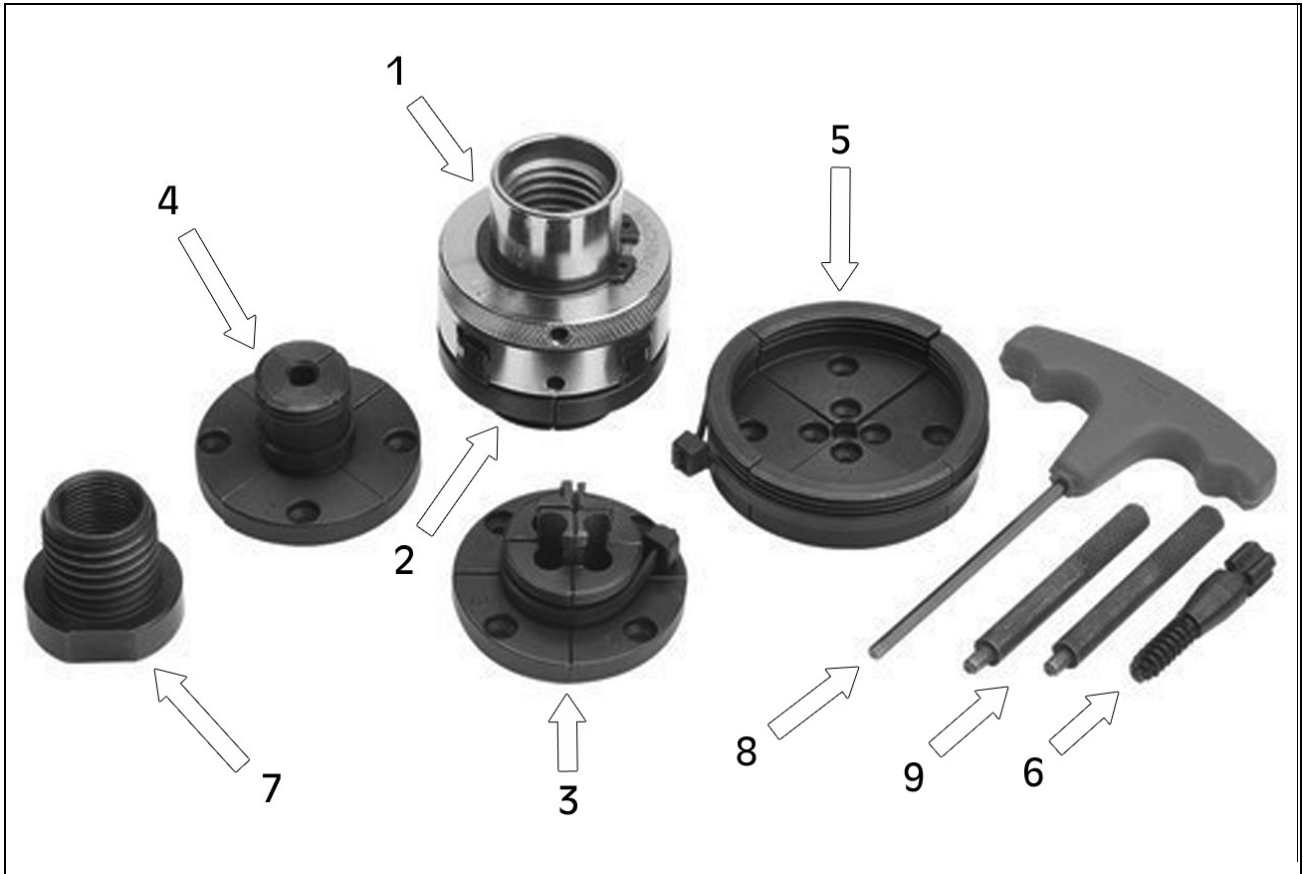

Item	Description
1	Mini Chuck
2	Round Jaw Set (Comes Attached to Mini Chuck)
3	Step Jaw Set
4	Extended Pin Jaw Set
5	Large Diameter Jaw Set

Item	Description
6	Screw Chuck
7	3/4" UNF x 16TPI Adapter
8	T-handle Hexagon Wrench
9	Tightening Levers
10	Carry Case (Not Shown)

SAFETY WARNINGS



CAUTION: ALWAYS READ THE SAFETY WARNINGS SUPPLIED WITH THE LATHE BEFORE USING THESE OR ANY OTHER ACCESSORIES.

1. **Stay alert, watch what you are doing and use common sense when operating a power tool. DO NOT** use a power tool while you are tired or under the influence of drugs, alcohol or medication. A moment of inattention while operating power tools may result in personal injury.
2. **Use personal protective equipment. ALWAYS** wear eye protection. Safety equipment such as dust mask, non-slip safety shoes, hearing protection and a workshop apron capable of stopping small abrasive or workpiece fragments.
3. **Avoid accidental starting.** Ensure the switch is in the off position before plugging in. Plugging in power tools that have the switch on invites accidents.
4. **Remove any adjusting key or wrench before turning the power tool on.** A wrench or a key left attached to a rotating part of the power tool may result in personal injury.
5. **Do not overreach.** Keep proper footing and balance at all times. This enables better control of the power tool in unexpected situations. Dress properly. **DO NOT** wear loose clothing or jewellery.
6. Keep your hair, clothing and gloves away from moving parts. Loose clothes, jewellery or long hair can be caught in moving parts. Keep the work area clean and tidy.
7. Regularly clean the power tool's air vents. The motor fan will draw dust inside the housing and accumulation of material could cause electrical hazards.
8. **Avoid operator fatigue.** Stop the power tool at regular intervals for a short break to rest hands and arms.
9. **Maintain your tools.** Keep all handles and grips dry and clean.
10. Make sure the chucks and adapter are fitted tightly on the lathe before turning on.
11. Keep lathe and all accessories out of reach of children.

ACCESSORIES



CAUTION: ALWAYS DETACH THE MINI CHUCK FROM THE LATHE BEFORE CHANGING THE JAW SETS.

SCREW CHUCK

The screw chuck is used to centrally hold a workpiece. It is clamped centrally between the 4 jaws of the mini chuck. To extend the length of the chuck, it can be used in conjunction with any of the jaw sets.

To attach the chuck, drill a single central shallow hole in the workpiece and screw the screw chuck in. Then mount the screw chuck into the main mini chuck.

Dimensions

Diameter: 6.5mm - 10mm

Length: 35mm

Screw Chuck



ATTACHING THE JAW SETS

Each section of a jaw set is numbered 1 to 4. Each section should be attached to the corresponding number on the mini chuck.

NOTE: Make sure that the pin on section 4 of each jaw set sits in the locking groove of the mini chuck.

Groove

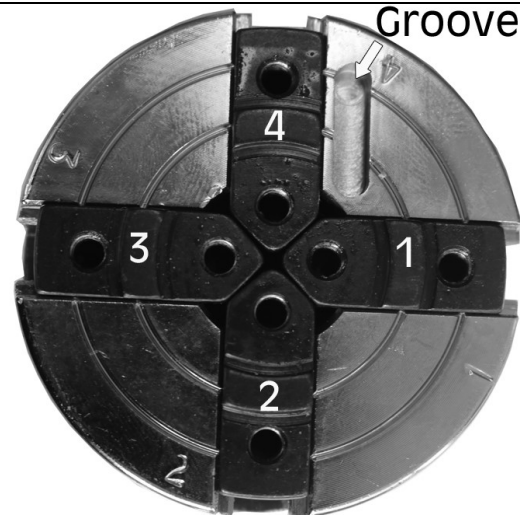

Using the T-handle hexagon wrench, screw each section onto the mini chuck using the two screws per section supplied.

NOTE: The extended pin jaw set only has one screw per section to attach to the mini chuck due to the design of the jaw set.

Extended Pin Jaw Set Dimensions

Min. Diameter: 22mm
Max. Diameter: 35mm

Extended Pin Jaw Set

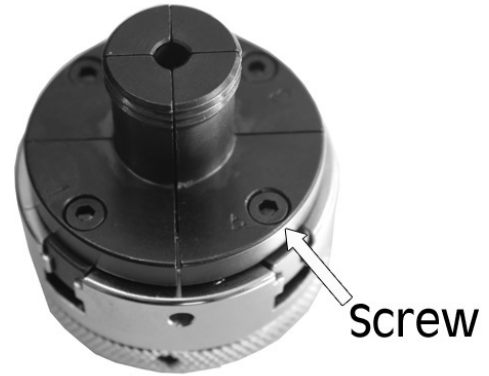

Large Diameter Jaw Set Dimensions

Min. Internal Diameter: 55mm
Max. Internal Diameter: 68mm

Min. External Diameter: 65mm
Max. External Diameter: 78mm

Large Diameter Jaw Set

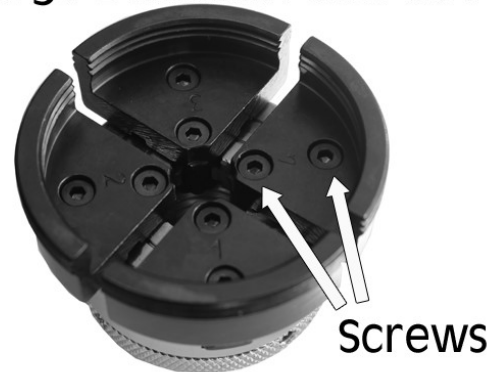

Round Jaw Set Dimensions

Min. Internal Diameter: 24mm
Max. Internal Diameter: 34mm

Min. External Diameter: 38mm
Max. External Diameter: 48mm

Round Jaw Set

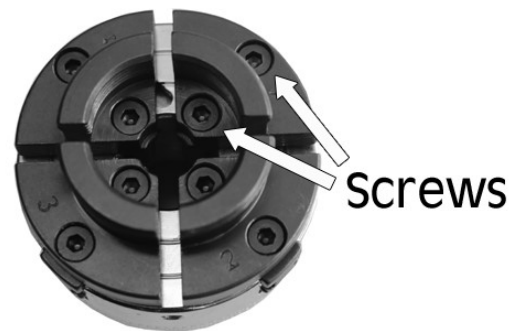

Step Jaw Set Dimensions

Min. Top Step Diameter: 16mm
Max. Top Step Diameter: 29mm

Min. Bottom Step Diameter: 30mm
Max. Bottom Step Diameter: 43mm

Step Jaw Set

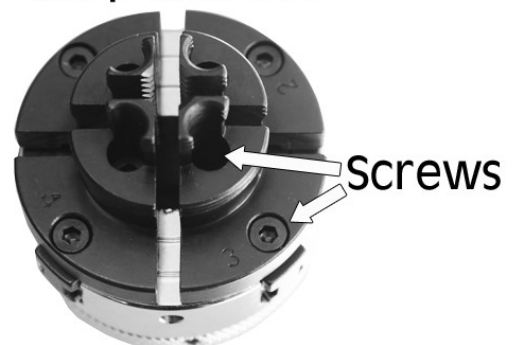

ASSEMBLY

1. Screw the 3/4" UNF x 16TPI adapter onto the headstock spindle of the lathe as shown, and tighten.

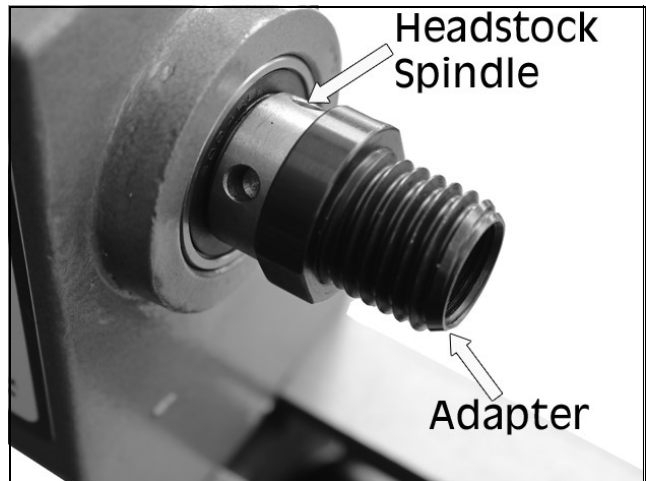

2. Screw the mini chuck (with appropriate jaw set attached, see pages 4-5) on to the adapter as shown.



3. Using the tightening levers, adjust the jaw set so it grips the workpiece.

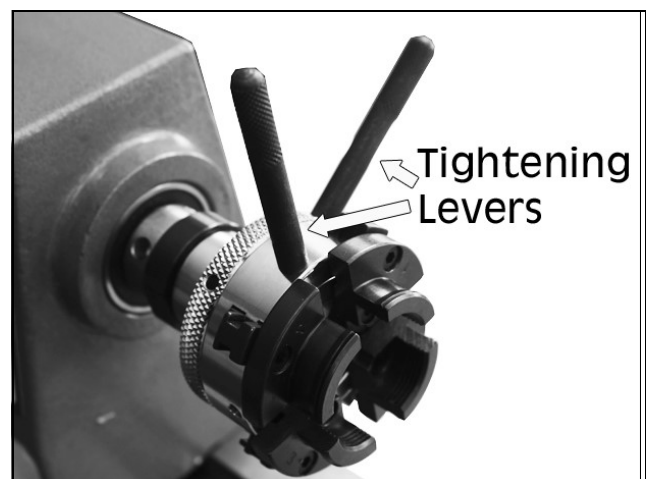

ENVIRONMENTAL PROTECTION

Recycle unwanted materials instead of disposing of them as waste. All unwanted accessories and packaging should be sorted and taken to a recycling centre for disposal in a manner which is compatible with the environment.

GUARANTEE

This CLARKE product is guaranteed against faulty manufacture for a period of 12 months from the date of purchase. Please keep your receipt as proof of purchase. This guarantee does not effect your statutory rights.

This guarantee is invalid if the product is found to have been abused or tampered with in any way, or not used for the purpose for which it was intended.

Faulty goods should be returned to their place of purchase, no product can be returned to us without prior permission.

A SELECTION FROM THE VAST RANGE OF

Clarke®

QUALITY PRODUCTS



AIR COMPRESSORS
From DIY to industrial, Plus air tools, spray guns and accessories.

GENERATORS
Prime duty or emergency standby for business, home and leisure.

POWER WASHERS
Hot and cold, electric and engine driven - we have what you need

WELDERS
Mig, Arc, Tig and Spot. From DIY to auto/industrial.

METALWORKING
Drills, grinders and saws for DIY and professional use.

WOODWORKING
Saws, sanders, lathes, mortisers and dust extraction.

HYDRAULICS
Cranes, body repair kits, transmission jacks for all types of workshop use.

WATER PUMPS
Submersible, electric and engine driven for DIY, agriculture and industry.

POWERTOOLS
Angle grinders, cordless drill sets, saws and sanders.

STARTERS/CHARGERS
All sizes for car and commercial use.



PARTS & SERVICE: 0208 988 7400

Parts Enquiries
Parts@clarkeinternational.com

Servicing & Technical Enquiries
Service@clarkeinternational.com

SALES: UK 01992 565333 or Export 00 44 (0)1992 565335

Clarke® INTERNATIONAL Hemnall Street, Epping, Essex CM16 4LG
www.clarkeinternational.com